

Документ подписан простой электронной подписью

Информация о владельце:

ФИО: Алеиник Станислав Николаевич

Должность: Ректор

Дата подписания: 2024.05.23 12:51

Уникальный программный ключ:

5258223550ea97beb23726a1609b644b35d8986ab6255891f288f913a1551fae

МИНИСТЕРСТВО СЕЛЬСКОГО ХОЗЯЙСТВА РОССИЙСКОЙ ФЕДЕРАЦИИ
ФЕДЕРАЛЬНОЕ ГОСУДАРСТВЕННОЕ БЮДЖЕТНОЕ
ОБРАЗОВАТЕЛЬНОЕ УЧРЕЖДЕНИЕ ВЫСШЕГО ОБРАЗОВАНИЯ
«БЕЛГОРОДСКИЙ ГОСУДАРСТВЕННЫЙ АГРАРНЫЙ УНИВЕРСИТЕТ
ИМ. В.Я.ГОРИНА»

Кафедра технической механики и конструирования машин
(наименование кафедры)

УТВЕРЖДЕН

на заседании кафедры

«06» 05 2024 г., протокол № 11-23/24

Заведующий кафедрой

Колесн.

А.С. Колесников

(подпись)

**ФОНД
ОЦЕНОЧНЫХ СРЕДСТВ**

ПО УЧЕБНОЙ ДИСЦИПЛИНЕ

Инженерная графика

(наименование дисциплины)

23.02.07 Техническое обслуживание и ремонт двигателей,
систем и агрегатов автомобилей

(код и наименование специальности)

специалист

Квалификация (степень) выпускника

п. Майский 2024 г.

« »

23.02.07

,

23

2020 . 657,

,
17.05.2012 . 413 (.
12.08.2022 . 732),

«

».

-

:

«

. . »

:

. . .

1.		4
2.		6
3.		7
4.	-	11
5.		32
6.		53

1.
1.1

« »

23.02.07

1.2

« »

:

- ;

- ;

-) () (

) () ,

:

:

1.3

:

;

,

;

,

;

- ;

,

:

;

,

;

;

(-) (-);

,

;

;

,

;

1.4

/			
1	2	3	4
1		<p>(-) , , .</p>	
2		<p>.</p>	
3		<p>,</p>	
4		<p>) : , (, ,) , ;) , , - , ;) , , .</p>	
5		<p>— , . , — , . , , .</p>	
6	-	,	-

7			

2.

/	(*)	()
23.02.07 –			
1.			
1	1.1	01, 1.3,	02, 3.3
2	1.2	05, 1.3,	07, 3.3
2. (
1	2.1	05, 6.1,	07, 3.3
2	2.2	02, 3.3,	05, 6.2
3	2.3	01, 1.3,	05, 6.1
4	2.4	05, 3.3,	07, 6.2

/	(*)	(
5	2.5	05, 1.3,	07, 3.3
3.			
1	3.1	01, 1.1,	05, 1.2
2	3.2 ,	05, 6.1,	02, 6.3
3	3.3 ·	05, 6.1,	07, 6.2
4	3.4 ·	05, 1.3,	07, 6.3
5	3.5	02, 1.2,	07, 2.3
6	3.6	02, 1.2,	05, 2.3
		01, 05, 1.3, 6.1-	02, 07, 3.3, 6.3

*

() ()

3.

/		
1	86-100%	
2	68-85%	
3	51-67%	
4	51%	

/			
1	<p>– ; –</p> <p>– ,</p> <p>– - ;</p> <p>–</p>	5	
2	<p>– ; –</p> <p>–) , :</p> <p>)</p> <p>) .</p>	4	
3	<p>– ;</p> <p>– ;</p> <p>) ,</p> <p>) ,) - ,</p> <p>) ,</p> <p>) ,4-5</p>	3	
4	<p>– ,</p> <p>« » ;</p> <p>–</p> <p>10</p>	2-0	

-

	90-100	
	75-89	
	60-74	
	60	

/			
1	,	5	
	,		
	,		
	,		
	,		
	,		
	,		
	,		
2	,	4	
	,		
	,		
	,		
	,		
	,		
	,		
	,		
3	,	3	
	,		
	,		
	,		
	,		
	,		
4	,	2-0	
	,		
	,		
	,		
	,		
	,		

4.
4.1
4.1.1

1.

1.

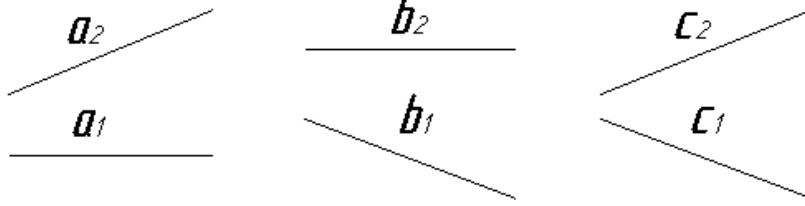

1) a; 2) b; 3) c.

2.

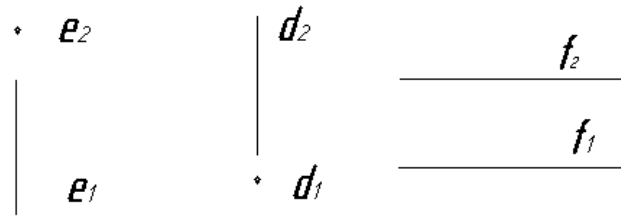

1) e; 2) d; 3) f.

3.

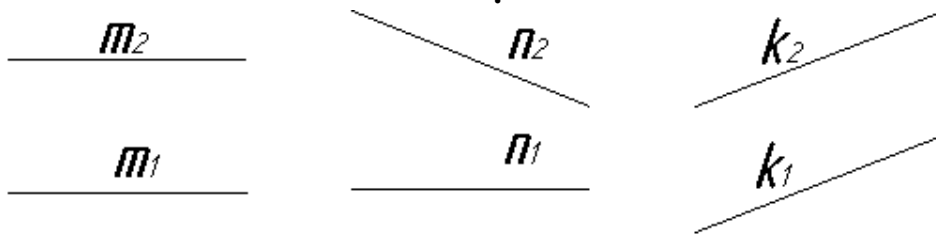

1) m; 2) n; 3) k.

4.

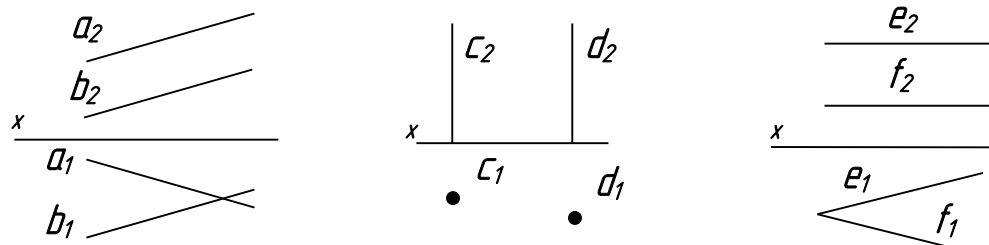

1) a // b; 2) c // d; 3) e // f.

5.

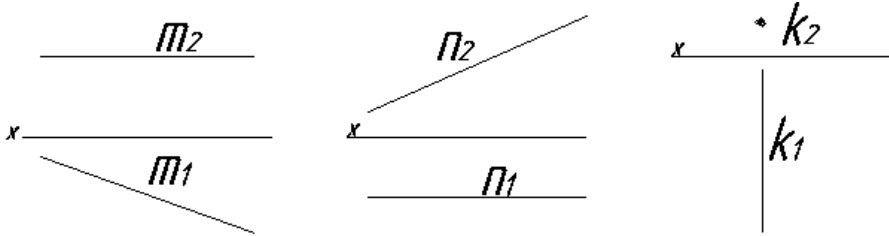

1) m; 2) n; 3) k.

6.

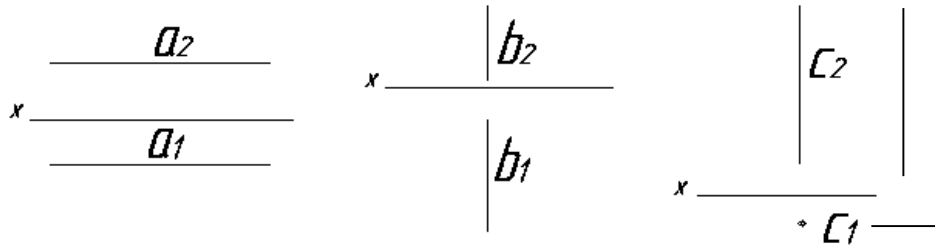

7. 1) a; 2) b; 3) c.

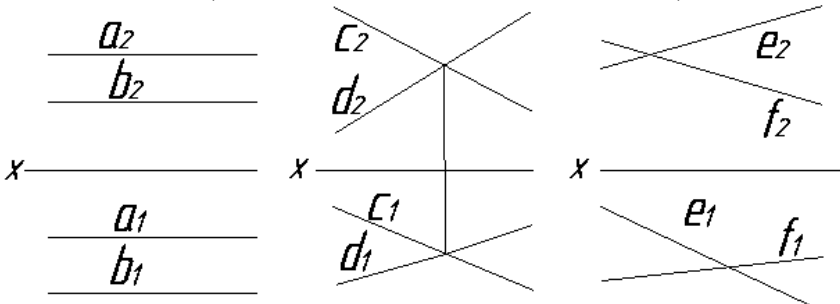

7. 1) a b; 2) c d; 3) e f.

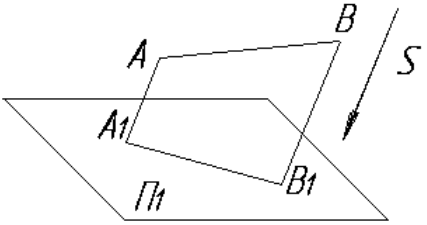

8. 1) ;
2) ;
3) ;
4) .

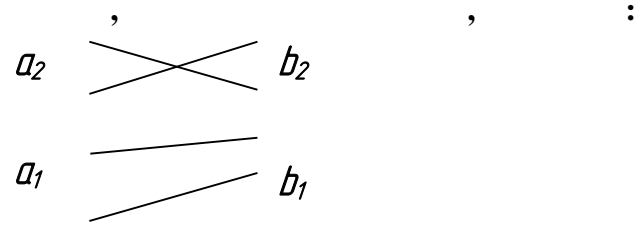

9. 1) ;
2) ;
3) .

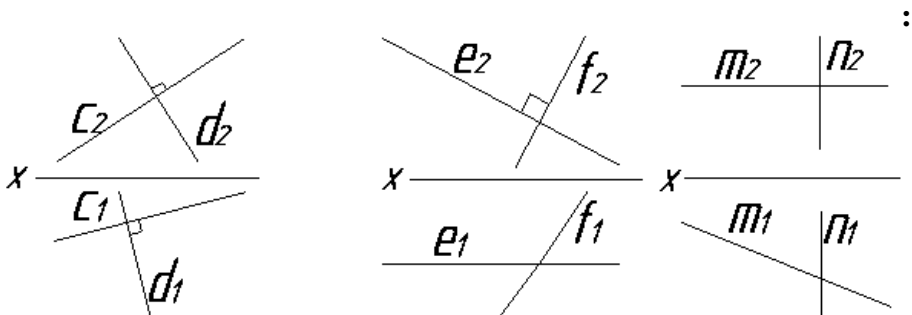

10. 1) c d; 2) e f; 3) m n.

1. 1.1...2 . ()

- 2.0,4...1,5 .
- 3.0,5...1,4 .
- 4.1,5...2,5

2.

- 1.
- 2.
- 3.
- 4.

3.

- 1. S/2
- 2. 3S
- 3. 1,5S

4.

- 1. ,
- 2. ,
- 3. ,
- 4. ,

5.

- 1.
- 2.
- 3.
- 4. +

6.

- 1.
- 2.
- 3.
- 4.

7.

5

- 1.
- 2.
- 3.

8.

- 1.
- 2. , 4
- 3.
- 4.

9.

2

- 1.
- 2.
- 3.

10.

- 1.
- 2.
- 3.
- 4.

11.

- 1. 70^0
- 2. + 75^0
- 3. 65^0
- 4. 80^0

(S)

12.

- 1. 1:2
- 2. 1:1
- 3. 2:1

13.

- 1. 2
- 2. 2,5
- 3. 3
- 4. 4
- 5. 5

14.

4

- 1.
- 2.
- 3.
- 4.

0
1

1 4
0 4

15.

- 1.
- 2.
- 3.
- 4.

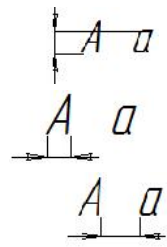
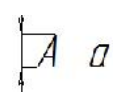

16.

2.302-68

(

2

)

- 1. 25:1
- 2. 15:1
- 3. 1:15
- 4. 1:25

17.

2.302-68

(

2

)

- 1. 2:1
- 2. 2 1
- 3. 2,5:1
- 4. 2.5:1

18.

2.104-68

3

(

2

)

- 1.
- 2.
- 3.
- 4.

19.

- 1.
- 2.
- 3.
- 4.

3.

1.

, . , ,

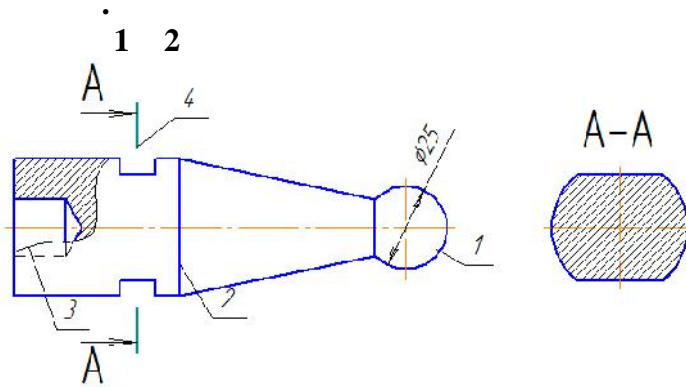

- 1.
- 2.
- 3.
- 4.

2.

2.104-68,

3 5

					1			
Изм.	Лист	№ докум.	Подп.	Дата	2	Лит.	Масса	Масштаб
Разраб.	6	7	8					4
Проб.						Лист	Листов	1
Н.контр.								5
Утв.								

- 1.
- 2.
- 3.
- 4.

3.

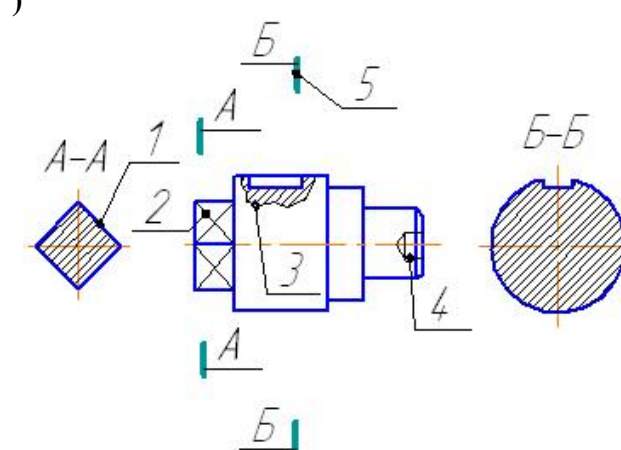

- 1.
- 2.
- 3.
- 4.

4.

2.302-68 «

»

(

2

)

1. 6:1
2. 10:1
3. 5:1
4. 3:1

5.

« ... (2) »

1.

Изм	Лист	№ докум	Подп	Дата	Лист	Масса	Масштаб
Разработ							
Проект							
Технича					Лист		Листов
Начальн							
Упр							

2.

						Лист
Изм	Лист	№ докум	Подп	Дата		
						Лист

3.

						Лист
Изм	Лист	№ докум	Подп	Дата		

4.

Изм	Лист	№ докум	Подп	Дата	Лист	Лист	Листов

6.

- 1.
- 2.
- 3.
- 4.

7.

- 1.
- 2. ,
- 3.
- 4.

8.

- 1. 3
- 2. 4
- 3. 5
- 4. 6

9.

- 1.
- 2.
- 3.
- 4.

10.

- 1.
- 2.
- 3.
- 4.

11.

1. () - ,
2. ,
3. ,
4. ,

12.

- 1.
- 2.
- 3.
- 4.

13.

1. , ,
2. , ,
3. , ,
4. , ,

14.

1. ,
2. ,
3. ,
4. ,

15.

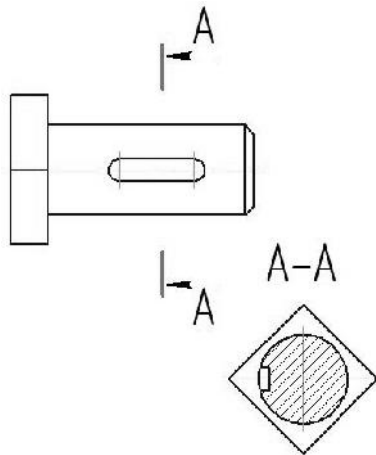

- 1.
- 2.
- 3.
- 4.

16.

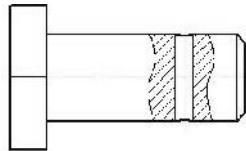

1. +
- 2.
- 3.
- 4.

17.

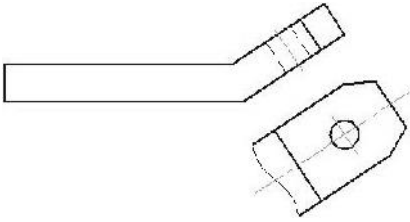

1.
2.
3.
4.
- 18.**

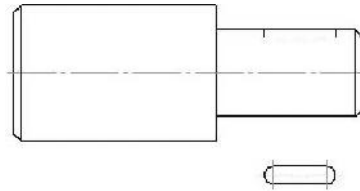

1.
2.
3.
4.
- 19.**

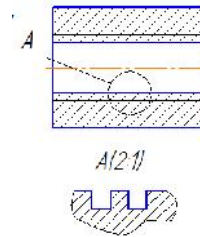

1.
2.
3.
4.
- 20.**

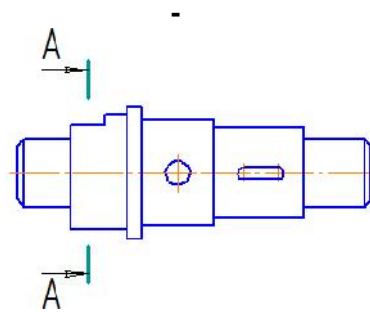

- A-A
1. A-A
2. A-A
3. A-A

21.

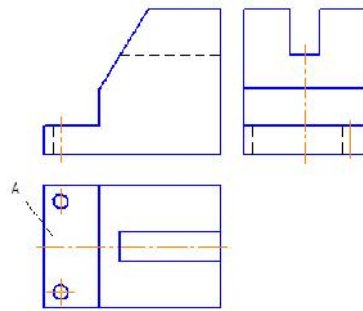
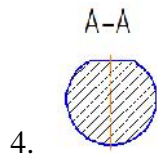

22.

- 1.
- 2.
- 3.
- 4.

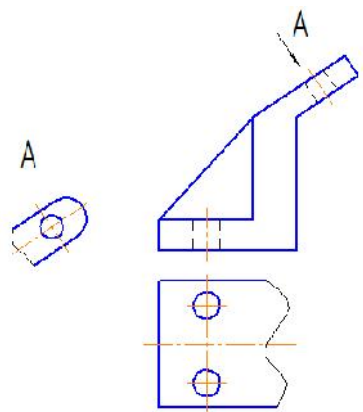

23.

- 1.
- 2.
- 3.
- 4.

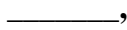

24.

- 1.
- 2.
- 3.
- 4.

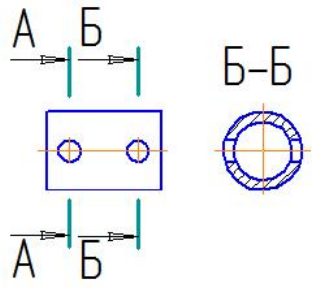

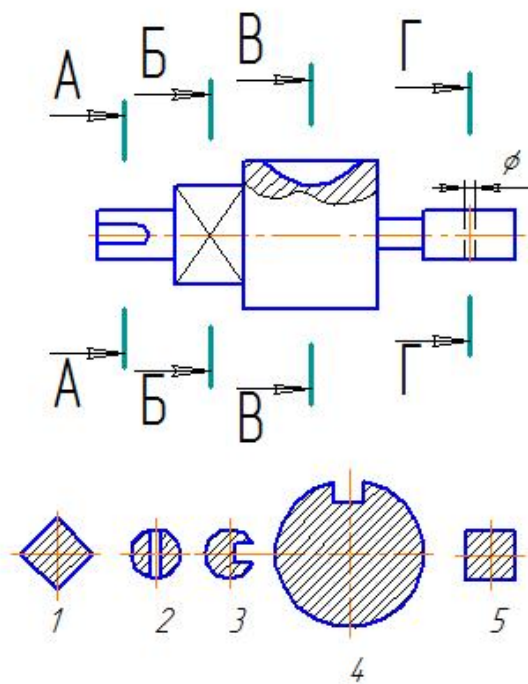
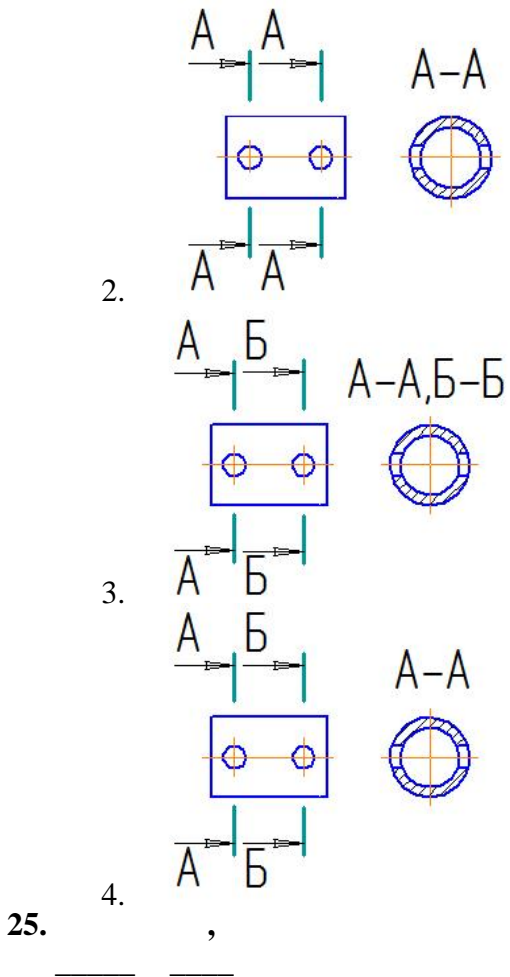

26. 1. -
 2. -
 3. -
 4. -

26. _____, _____

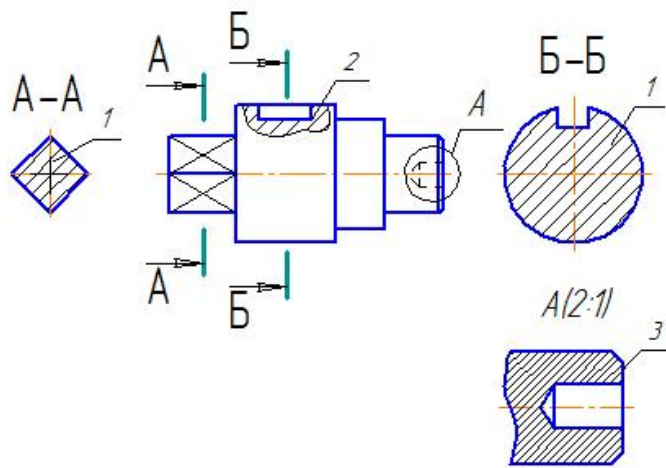

- 1.
- 2.
- 3.
-) 3
-) 2
-) 1
-)

27.

3 4

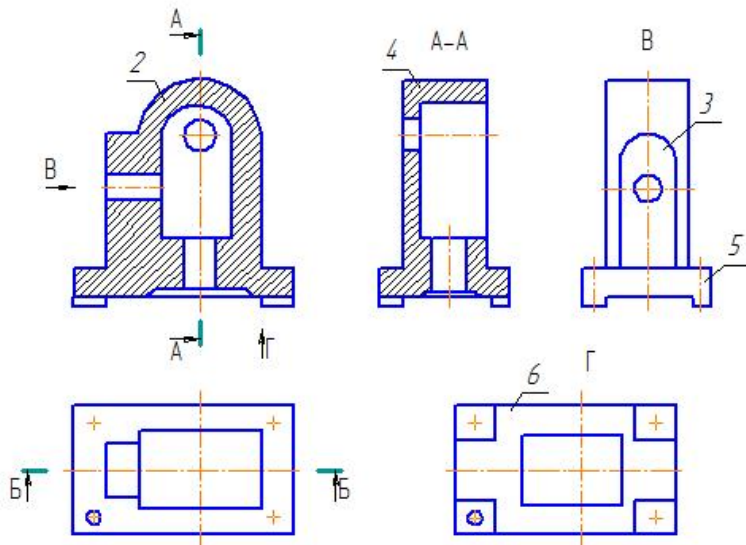

- 1.
- 2.
- 3.
- 4.

28.

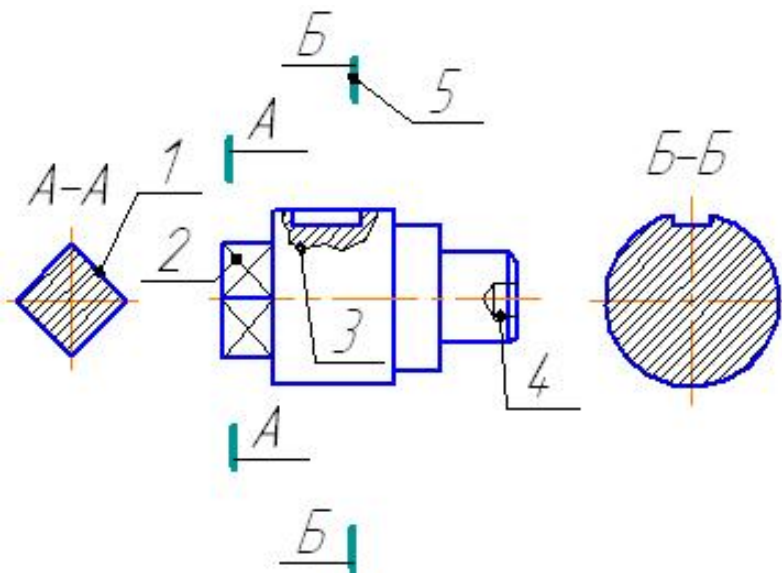

- 1. 2
- 2. 1
- 3. 3

29.

_____ . (_____)

4 5

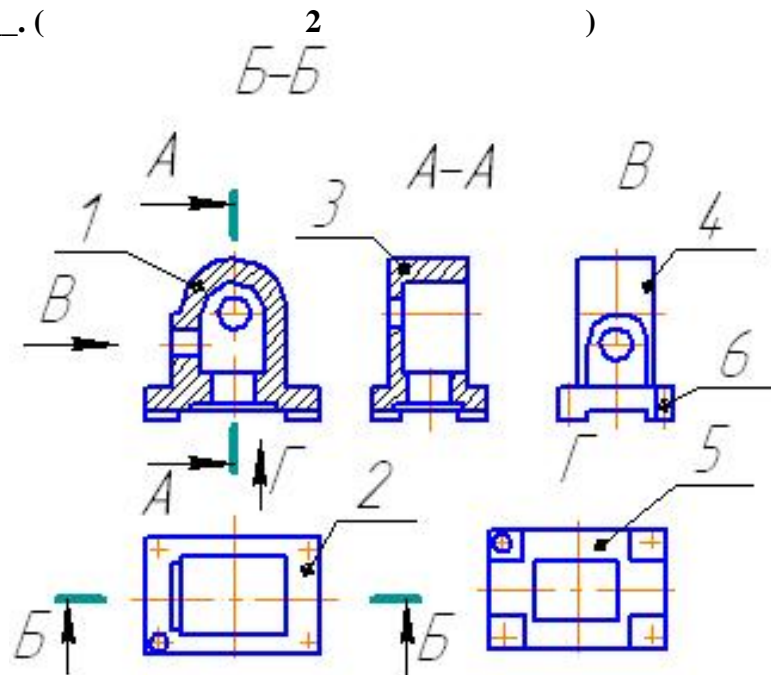

- 1.
- 2.
- 3.
- 4.

4.2
4.2.1

(_____)

1.

1 (_____ 1 2).

				<i>НГИГ 15ХХ.000000.00.00</i>			
<i>Изм./Лист</i>	<i>№ докум.</i>	<i>Подп.</i>	<i>Дата</i>	<i>Название работы</i>	<i>Лист</i>	<i>Масса</i>	<i>Масштаб</i>
<i>Разраб.</i>	<i>Иванов И.И.</i>						1:1
<i>Проб.</i>	<i>Петров П.П.</i>				<i>Лист</i>	<i>Листов</i>	
<i>Т.контр.</i>							
<i>Н.контр.</i>				<i>Белгородский ГАУ</i>			
<i>Утв.</i>				<i>группа Т.Сист - 11</i>			
				<i>Копировал</i>	<i>Формат А3</i>		

НГИГ 15ХХ.000000.00.00
 № работы /
 Две последние цифры зачетной книжки
 Год
 Начертательная геометрия. Инженерная графика

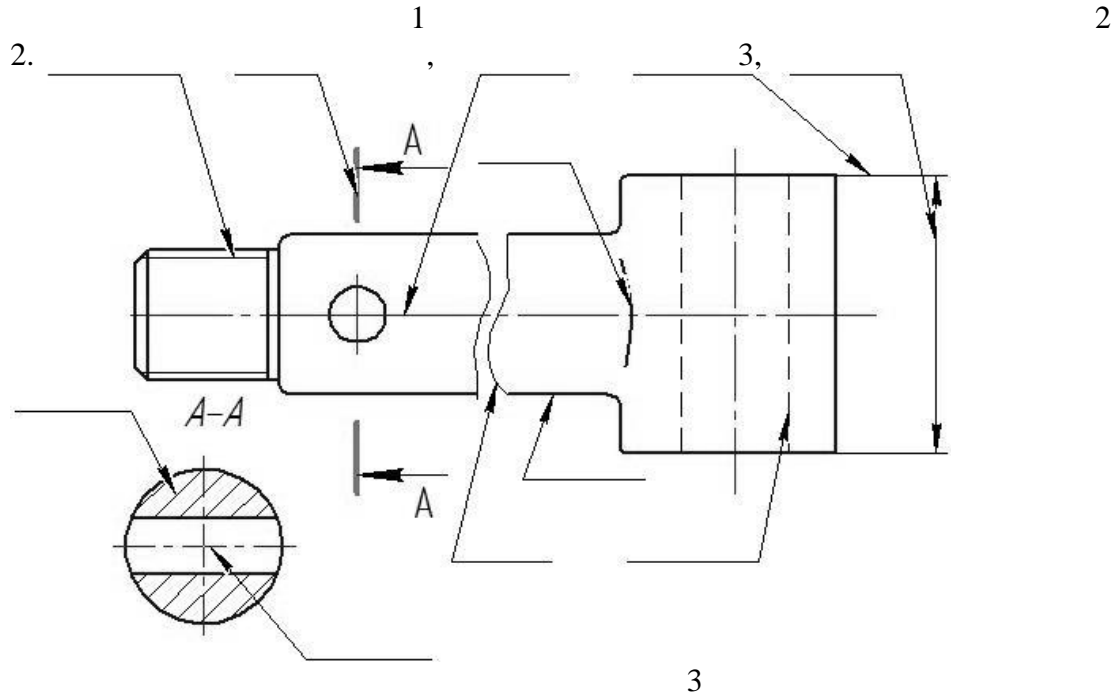

1		2		3	
---	--	---	--	---	--

4		5		6	
7		8		9	
10		11		12	
13		14		15	
16		17		18	

1		2	3
4		5	6
7		8	9
10		11	12

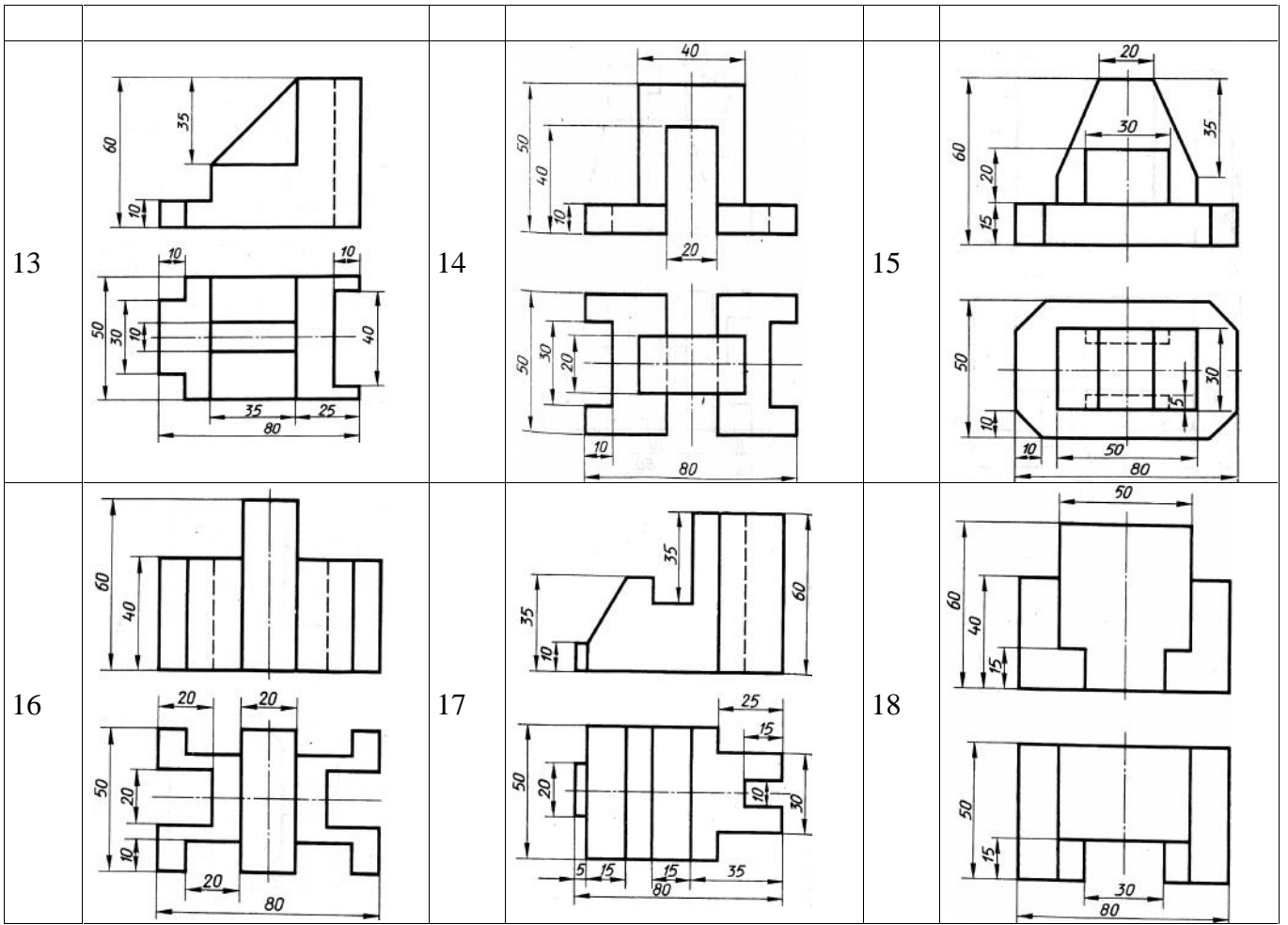

4.2.2 -

3.

«
 ». « » (« »)
 , , -
 , . « » : ,
 , 1,5-2 . « » : « »,
 ()
 : ;
 () ;
 (, , ,). ;
 ():
 1.

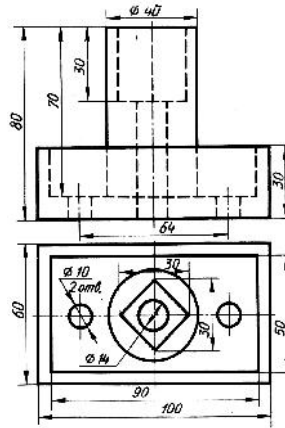

2.

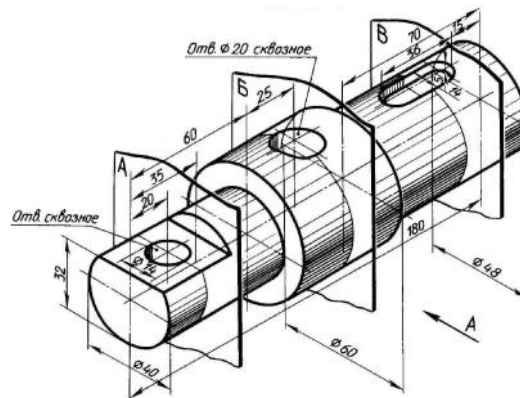

3.

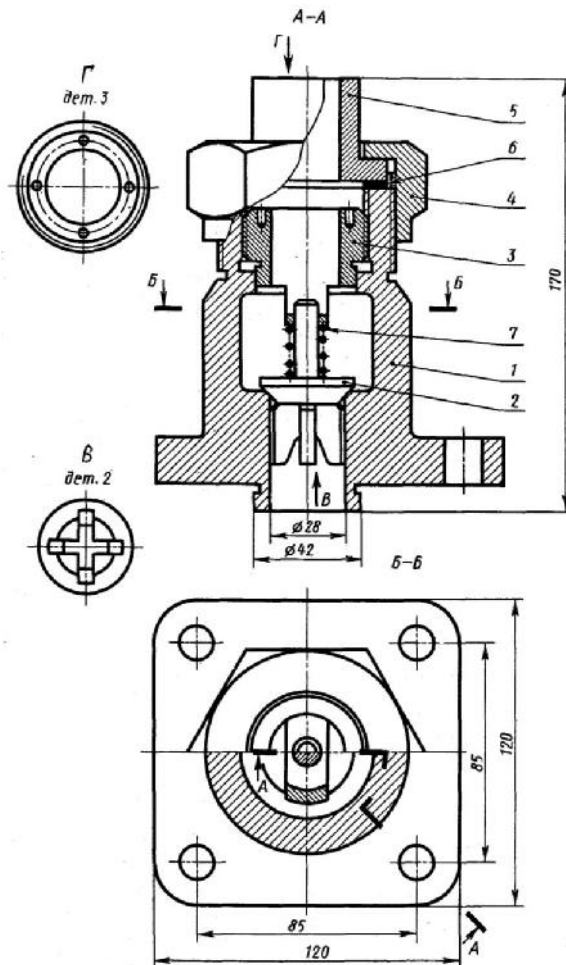

72 4 1 . . 4; 50

3.

2 . ,

1.

3 1 (50), , 7 , 2

4 (72 4)

(5). 5

6

1. 5

7 7

2.

5. 2 7

4.3



4.3.1

1. . ?
2. . .
3. .
4. .
5. ?
6. ,
7. .
8. .
9. ?
10. .
11. ?
12. ,
13. ?
14. , ,
15. ?
16. .
17. .
18. () ?
19. () ?
20. .
21. .
22. .
23. .

- 24.
- 25.
- 26.
- 27.
- 28.
- 29.
- 30.
- 31.
- 32.
- 33.
- 34.
- 35.
- 36.
- 37.
- 38. ?
- 39.
- 40.
- 41.
- 42.
- 43.
- 44.
- 45.
- 46.
- 47.
- 48.
- 49.
- 50.
- 51.
- 52.
- 53.
- 54.
- 55.
- 56. ?
- 57.
- 58. ?
- 59.
- 60.

4.3.2.

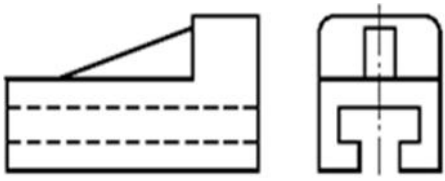
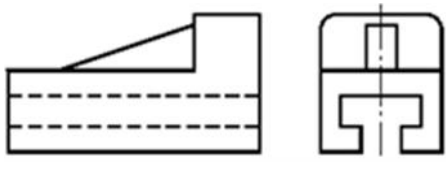
1.		2.	
----	--	----	--

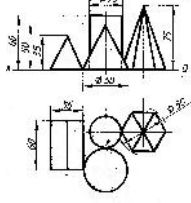
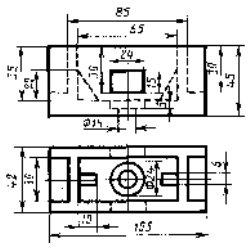
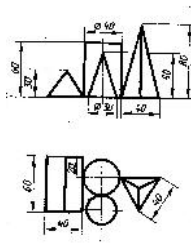
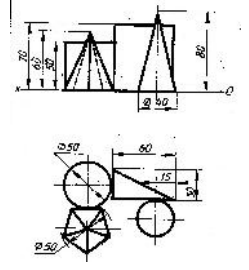
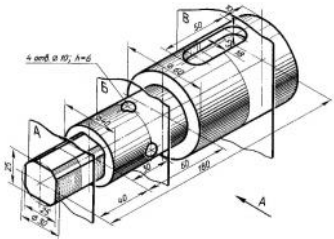
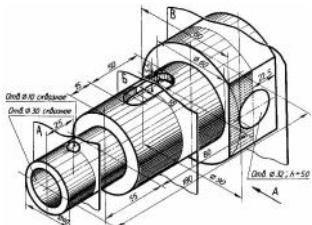
3.		4.	
5.		6.	
7.		8.	
9.		10.	<p>() « »</p> 
11.	<p>() « »</p> 	12.	<p>(90;60;20), (40;10;50), (10;50;10), L(80;70;40), (20;10;0)</p> <p>LM.</p> <p>LM</p>
13.	<p>(130;70;35), (50;10;100), (0;40;50), D(125;25;10), (70;15;50), (15;90;45)</p>	14.	<p>(100;15;30), (45;50;60), (10;20;15)</p>

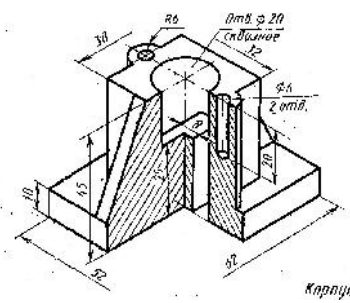
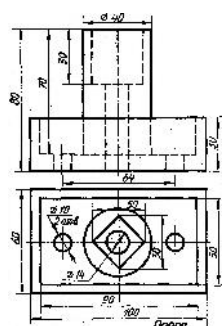
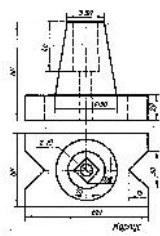
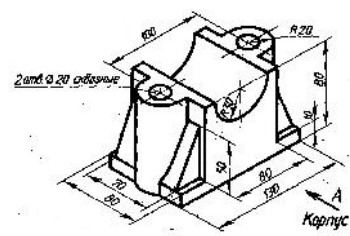
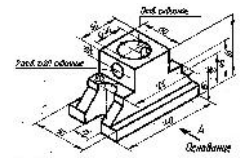
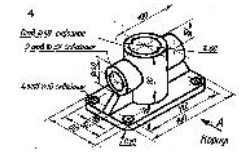
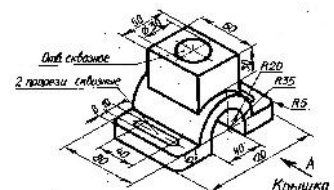
	D		
15.	(130;70;35), (50;10;100), (0;40;50), D(125;25;10), (70;100;50), (15;90;90) D	16.	(100;10;30), (40;50;60), (10;20;5)
17.		18.	
19.		20.	
21.		22.	
23.		24.	

- 2.
- 3.
- 4.
- 5.

?

3.

- 1.
- 2.
- 3.
- 4.
- 5.

5.2

1

2.301 - 68*

(1.1).

1.1

	0	1	2	A3	4
	841x1189	594x841	420x59	297x420	210 297

4 (4

).

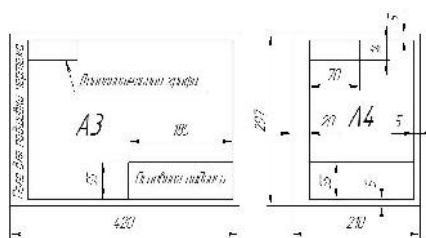

1.1

2.104 - 68*

(1)

(

1.2).

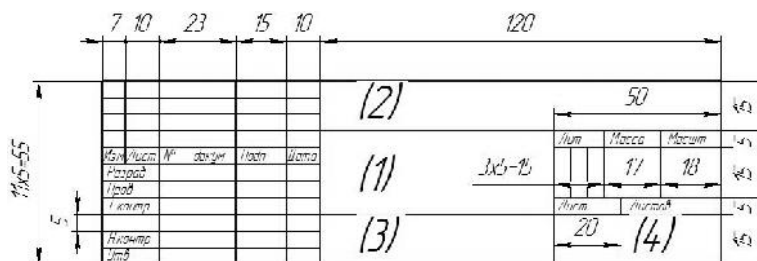

1.2

() :

- 1 - () ;
 - 2 - (16 01.000000.01);
 - 3 - (10 1050-88);
 - 4 - () .
- (2.304-81, 75°)

1.2

:	
h ()	1,8; 2,5; 3,5; 5; 7; 10; 14; 20; 40; ...
	1,3; 1,8; 2,5; 3,5; 5; 7; ...
d	0,1h
	2d
	6d
	17d
σ	$\sigma = 5d$ $\sigma = 7d$ $\sigma = 8d$ $\sigma = 6d$
σ	$\sigma = 4d$ $\sigma = 6d$ $\sigma = 7d$ $\sigma = 5d$

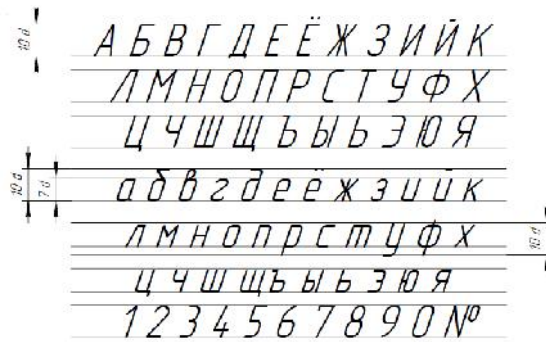

2.302 - 68*

1.3

	1:2; 1:2,5; 1:4; 1:5; 1:10; 1:15; 1:20; 1:25; 1:40; 1:50; 1:75; 1:100
	1:1
	2:1; 2,5:1; 4:1; 10:1; 20:1; 40:1; 50:1; 100:1

" "

: 1:2; - 1:2.

2.303 - 68

1.4

	S = 0,5 - 1,4	•
	S/3 - S/2	•
	S/3 - S/2	•
	S/3 - S/2	•
	S/3 - S/2	•
	S - 1,5S	•

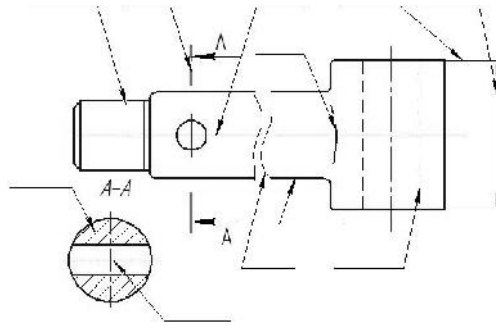

1.3

- 1.
- 2.
- 3.
- 4.

2

2.1

, , , D,

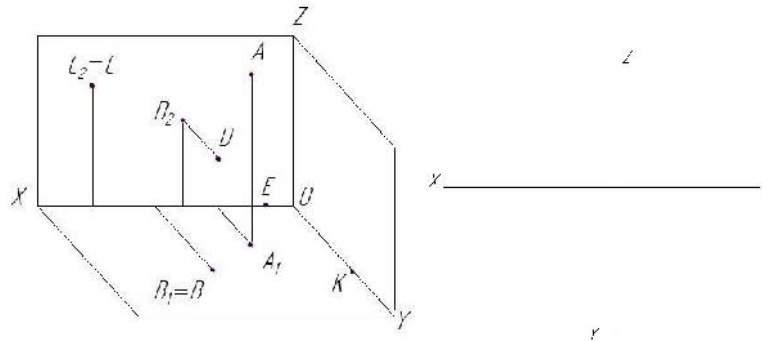

A _____ C _____ E _____
 B _____ D _____ K _____

2.2

A, B, C, D (2.1)

2.2

2.1

	A			B			C			D				A			B			C			D		
	x	y	z	x	y	z	x	y	z	x	y	z		x	Y	z	x	y	z	x	y	z	x	y	z
1	10	20	30	0	20	30	25	0	15	20	40	0	10	30	20	15	20	30	0	0	30	40	40	0	35
2	15	30	40	30	0	20	30	20	0	0	30	15	11	40	30	20	0	30	40	20	0	35	15	20	0
3	35	40	15	40	0	20	0	40	20	40	20	0	12	20	30	15	30	40	0	15	0	35	0	40	30
4	35	20	10	0	25	40	10	40	0	25	0	30	13	30	40	15	35	0	15	0	20	30	35	20	0
5	45	30	30	15	30	0	15	0	20	0	40	20	14	20	40	30	0	40	30	40	30	0	10	0	30
6	15	20	30	25	0	30	0	40	15	25	15	0	15	30	30	40	30	15	0	35	0	25	0	30	20
7	25	30	35	0	25	15	15	40	0	20	0	30	16	10	30	40	15	0	30	0	20	10	30	40	0
8	25	20	35	35	40	0	30	0	10	0	40	15	17	35	40	20	0	25	30	25	40	0	35	0	10
9	15	30	15	10	0	40	0	30	15	10	20	0	18	20	10	30	15	20	0	20	0	10	0	25	10

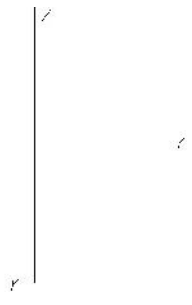

2.2

	1	2	3
Max			
Min			
	1		
	2		
	3		

2.3 *

A, B, C, D, E, F.

- 1) ;
- 2) ;
- 3) ;

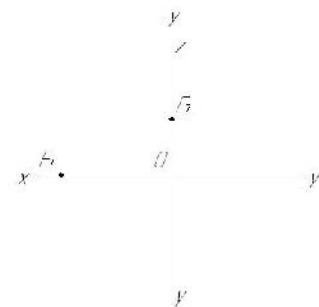
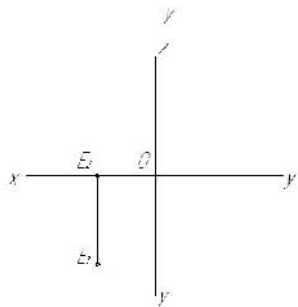
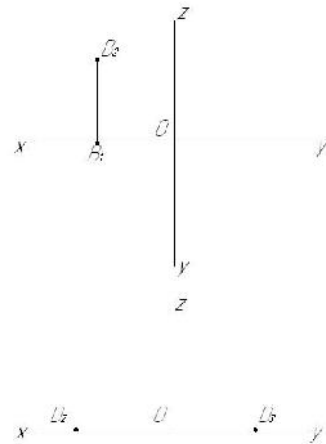
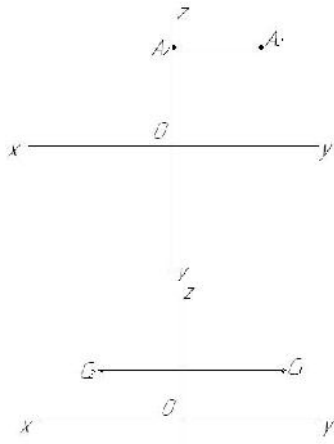

1. ()? ?
2. , ?
3. , ?
4. ? ?

3.1

: (30, 10, 25), (10, 5, 15).



3.2

(3.1).

3.1

	A			B				A			B				A			B		
	x	y	z	X	y	z		x	y	z	x	y	z		x	y	z	x	y	z
1	35	40	15	15	20	30	7	40	30	15	15	30	40	13	15	30	15	30	20	40
2	15	20	35	30	30	15	8	30	10	40	35	40	20	14	35	20	10	15	30	40
3	40	20	45	20	40	20	9	20	40	30	40	20	10	15	10	40	15	35	20	30
4	50	10	15	20	30	35	10	50	30	25	15	20	10	16	15	10	30	30	20	30
5	45	20	5	15	40	25	11	10	20	40	25	40	10	17	40	20	15	40	40	30
6	30	40	45	10	40	15	12	25	10	35	40	20	20	18	40	10	10	20	20	30



3.3

30 :

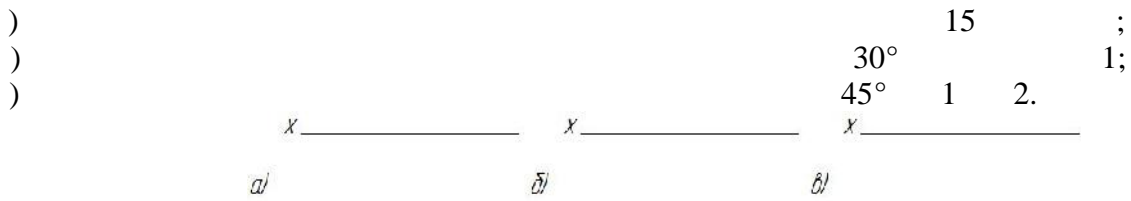

3.4

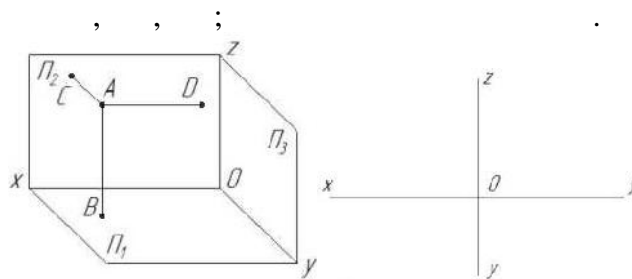

AB _____
AC _____
AD _____

3.5

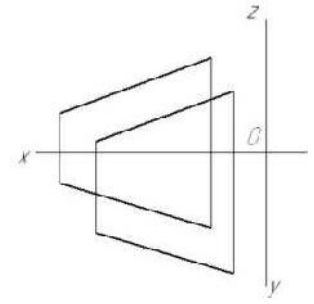
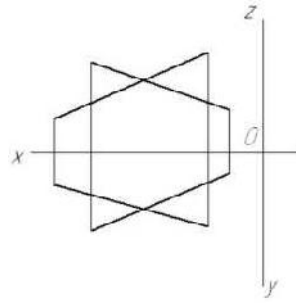
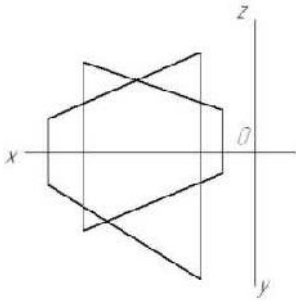

3.6 *

CD

(3.2)

3.2

	A			B			C			D				A			B			C			D		
	x	y	z	X	y	z	x	y	z	x	y	z		x	y	z	x	y	z	x	y	z	x	y	z
1	95	70	35	30	30	45	80	45	70	15	10	30	10	70	65	65	15	15	45	45	20	30	40	45	65
2	80	35	55	35	25	30	80	15	15	75	40	75	11	85	35	20	50	50	55	80	70	55	20	10	5
3	85	35	20	50	50	55	80	70	55	20	10	5	12	80	35	20	35	40	60	75	70	55	15	10	40
4	70	65	65	15	15	45	45	20	30	40	45	65	13	95	70	35	30	30	45	80	45	70	15	10	30
5	90	40	20	55	50	60	85	70	55	25	10	5	14	95	65	65	30	30	50	80	45	45	15	10	30
6	70	70	60	15	15	40	95	40	20	35	40	60	15	95	70	35	30	30	45	80	45	70	15	10	30
7	95	70	70	30	30	50	80	45	45	15	10	30	16	95	65	65	30	30	50	80	45	45	15	10	30
8	85	40	20	55	50	60	80	70	60	25	15	5	17	70	65	65	15	15	45	45	20	30	40	45	65
9	95	70	35	30	30	45	80	45	70	15	10	30	18	60	50	10	5	20	30	60	60	30	20	50	40

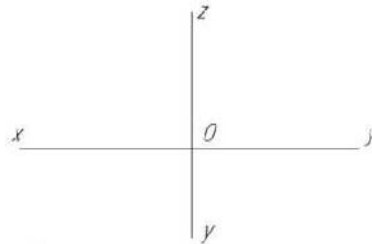

- 1.
- 2.
- 3.
- 4.

?
?
?

4

4.1

1, 2., 3.

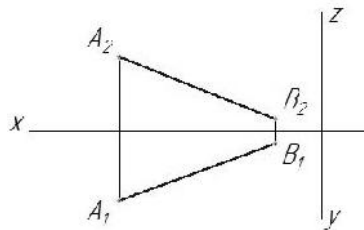

4.2 *

25

2.

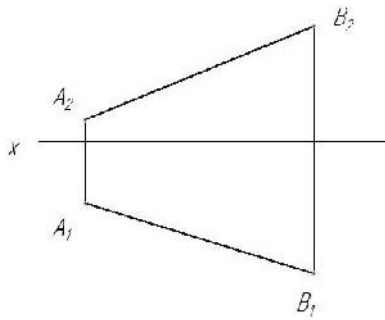

4.3

A, B (4.1)

4.1

	A			B				A			B				A			B		
	x	y	z	X	y	z		x	y	z	x	y	z		x	y	z	x	y	z
1	62	24	15	25	60	60	7	62	20	32	22	5	70	13	10	20	10	40	60	52
2	10	24	32	40	6	80	8	30	8	55	5	48	12	14	53	43	32	20	5	62
3	40	56	10	10	6	30	9	0	35	30	64	0	0	15	60	5	20	40	55	50
4	0	10	35	30	52	8	10	25	5	62	6	60	4	16	10	20	10	15	55	45
5	20	50	48	30	0	20	11	10	5	5	45	62	52	17	25	60	55	10	10	15
6	24	5	75	5	52	25	12	8	50	60	67	22	40	18	18	55	60	40	5	40

1.

?

2.

?

3.

4.

?

5

5.1

(5.1)

5.1

1	2	3
4	5	6

5.2

A, B, C (5.2)

5.2

	A	B	C		A	B	C
--	---	---	---	--	---	---	---

	x	y	z	x	y	z	x	y	z		x	y	z	x	y	z	x	y	z
1	62	24	15	25	60	60	10	40	25	10	25	5	62	6	60	4	70	25	20
2	10	24	32	40	6	80	62	52	45	11	10	5	5	45	62	52	60	15	30
3	40	56	10	10	6	30	65	15	58	12	8	50	60	67	22	40	30	5	5
4	0	10	35	30	52	8	60	30	50	13	10	20	10	40	60	52	68	5	32
5	20	50	48	30	0	20	53	10	0	14	53	43	32	20	5	62	0	0	20
6	24	5	75	5	52	25	68	45	10	15	60	5	20	40	55	50	10	10	10
7	62	20	32	22	5	70	10	55	15	16	10	20	10	15	55	45	55	5	25
8	30	8	55	5	48	12	65	30	0	17	25	60	55	10	10	15	35	60	25
9	0	35	30	64	0	0	35	55	65	18	18	55	60	40	5	40	5	5	10

5.3*

(55, 50, 50), (15, 25, 0), (95, 0, 15),
= 70, Z = 30,

ABC

5.4

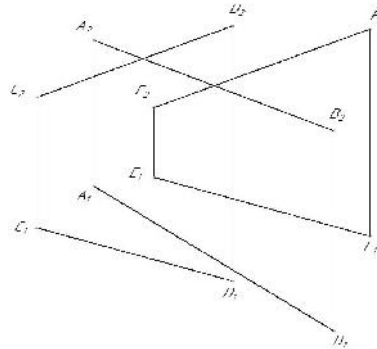

5.5

A, B, C (

5.2,

5.2)

DE (

5.3)

5.3

	D			E				D			E				D			E		
	x	y	z	X	y	z		x	y	z	x	y	z		x	y	z	x	y	z
1	60	55	63	5	25	35	7	70	40	65	15	10	5	13	73	10	47	20	15	10
2	70	50	80	5	12	12	8	60	40	35	10	15	5	14	7	45	65	51	10	10
3	4	56	64	58	11	5	9	50	55	82	10	20	0	15	55	45	55	35	5	5
4	65	55	60	5	5	10	10	64	46	6	3	3	65	16	50	5	10	10	35	35
5	60	30	50	10	15	5	11	40	5	10	55	57	57	17	60	50	55	7	18	27
6	65	55	80	15	5	5	12	52	5	10	15	30	25	18	2	35	17	60	45	67

6

6.1

MN

ABC DEK.

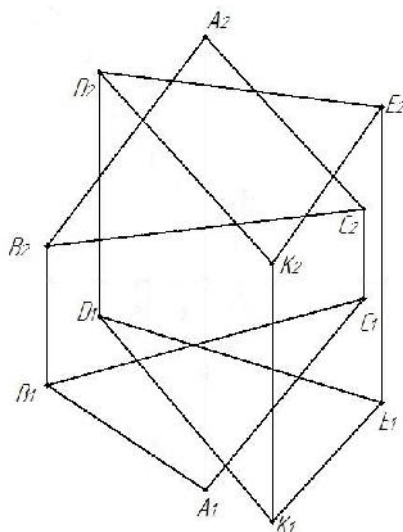

6.2

A, B, C, D, E, (6.1)
DEK.

MN

ABC DEK.

6.1

	A			B			C			D			E			K		
	x	y	z	x	y	z	x	y	z	x	y	z	x	y	z	x	y	z
1	120	90	10	50	25	80	0	85	50	70	110	85	135	20	35	15	50	0
2	18	90	10	83	25	79	135	83	48	67	110	85	0	19	36	121	52	0
3	18	40	9	83	111	79	135	47	48	67	20	85	0	111	36	121	78	0
4	20	40	10	85	110	80	135	48	48	70	20	85	0	110	35	120	80	0
5	100	25	82	40	95	0	0	55	40	125	75	50	0	40	100	25	85	0
6	115	90	10	52	25	80	0	80	45	65	105	80	130	18	35	12	50	0
7	117	40	9	52	111	79	0	47	48	68	20	85	135	111	36	14	78	0
8	120	92	10	50	20	75	0	80	46	70	115	85	135	20	32	10	50	0
9	130	105	35	40	10	100	0	40	0	125	25	10	70	100	110	0	70	70
10	15	10	85	80	80	20	130	50	80	70	80	108	0	35	20	120	0	50
11	15	25	60	82	100	0	125	45	50	65	20	90	125	100	0	15	80	50
12	16	12	88	85	80	25	130	50	80	75	85	110	0	30	15	120	0	50
13	18	12	85	85	80	25	135	50	80	70	85	110	0	35	20	120	0	50
14	115	7	85	50	110	25	0	50	85	70	85	110	135	40	20	15	0	50
15	115	10	92	50	80	25	0	50	85	70	85	110	135	35	20	15	0	50
16	18	10	90	83	79	25	135	48	83	67	85	110	0	36	19	121	0	52
17	20	12	92	85	80	25	135	50	85	70	85	110	0	35	20	120	0	52
18	116	8	88	50	78	25	0	46	80	70	85	108	135	36	20	15	0	52

- 1.
- 2.
- 3.
- 4.

?

?

?

7

7.1 *

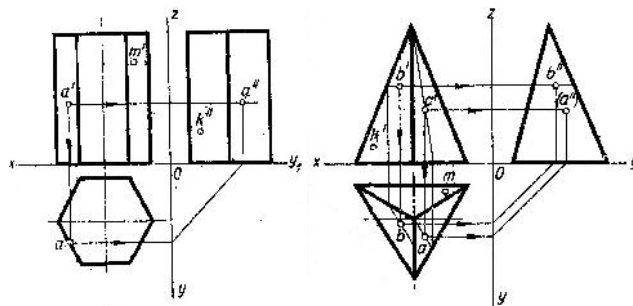

7.2

7.1)

(7.1

7.2)

(7.1).

(

	d	d ₁	h	h ₁		d	d ₁	h	h ₁
1	60	40	40	40	10	40	60	50	50
2	50	60	30	35	11	70	55	45	40
3	40	40	45	40	12	65	45	40	40
4	70	50	35	40	13	45	65	30	35
5	65	60	40	45	14	60	40	45	40
6	45	55	50	50	15	50	60	35	40
7	50	45	45	40	16	40	40	40	45
8	55	65	45	50	17	70	55	45	50
9	60	65	30	45	18	65	65	30	45

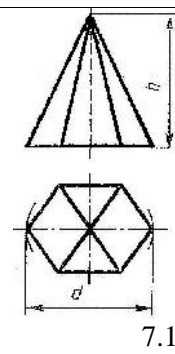

7.1

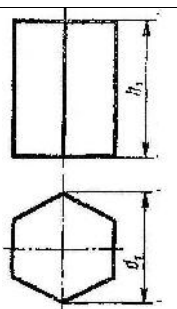

7.2

x

x _____

r

- 1.
- 2.
- 3.
- 4.

?

8

8.1

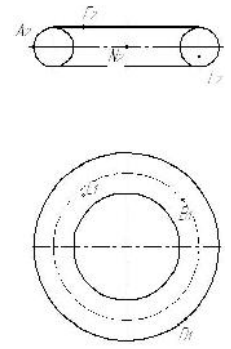
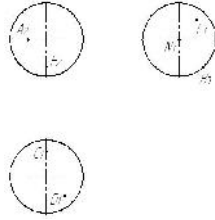
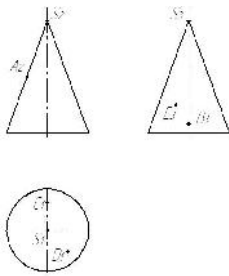

- 1.
- 2.
- 3.
- 4.

?

:

,

,

,

?

?

?

9.1

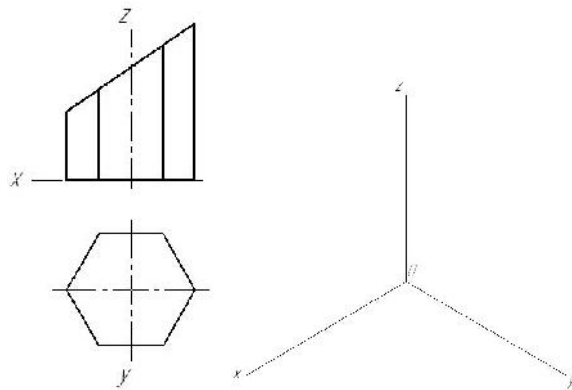

9.2

XOY, XOZ, YOZ.

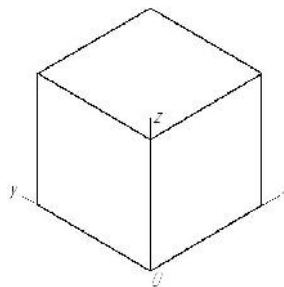

9.3 *

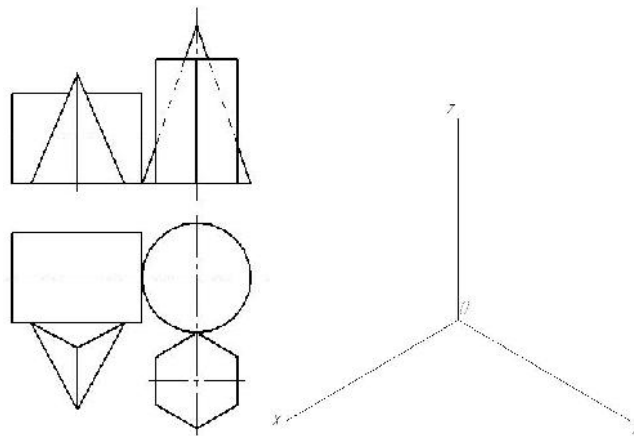

- 1.
- 2.
- 3.
- 4.

?

10

<p>10.1</p> <p>2</p>	<p>10.2</p> <p>,</p>
<p>10.3</p> <p>3</p>	<p>10.4</p> <p>2</p>
<p>10.5</p>	<p>10.6</p>

10.7

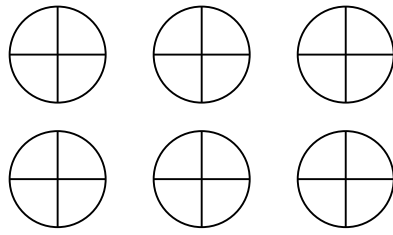

- 1.
- 2.
- 3.
- 4.

11

11.1

(11.1) 3

11.1

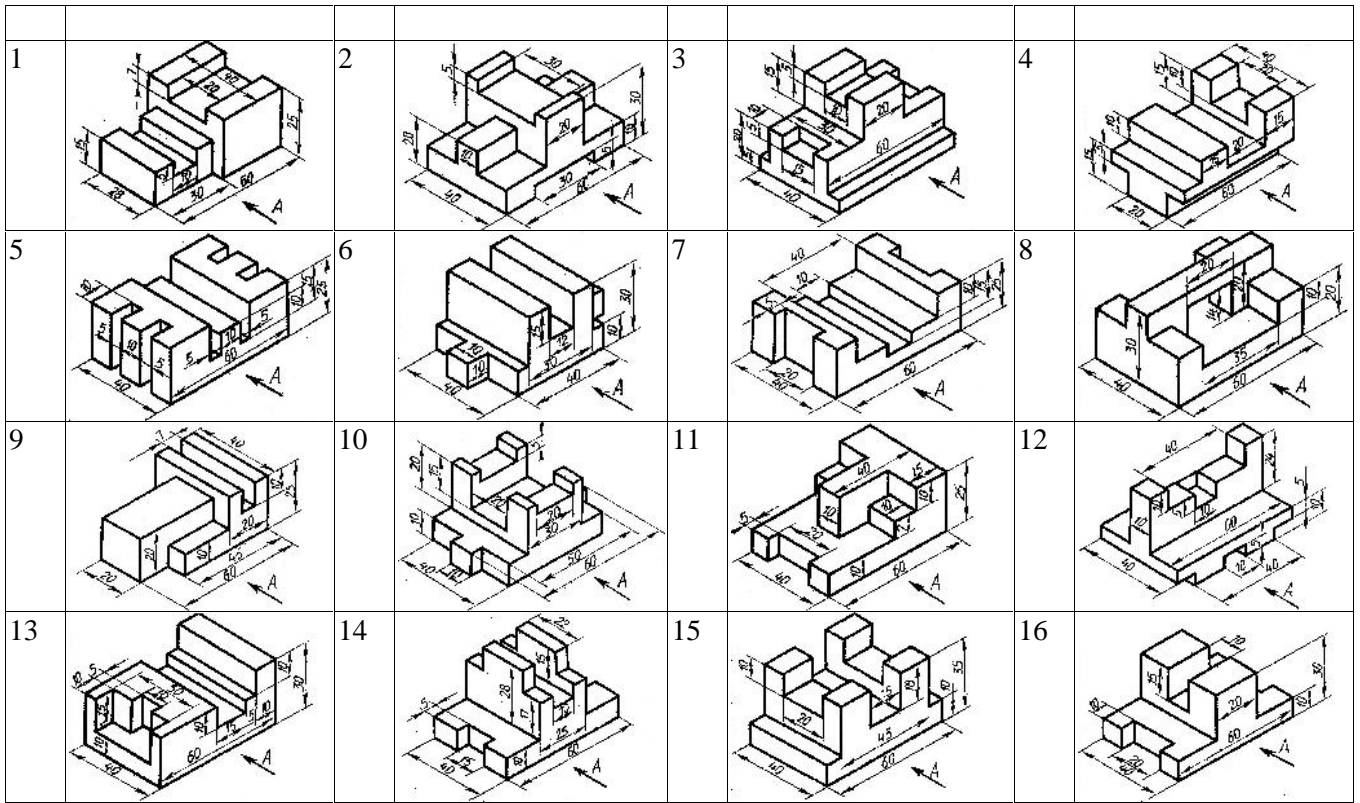

11.2

(11.2)

11.2

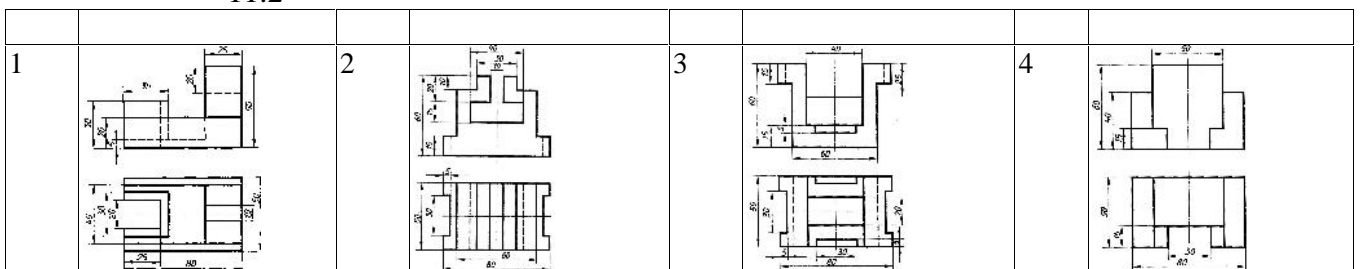

5		6		7		8	
9		10		11		12	
13		14		15		16	

1. ?
2. ,
3. , ?
4. ?
5. ?

12

12.1

(12.1)

12.1

1		2		3		4	
5		6		7		8	
9		10		11		12	
13		14		15		16	

12.2

(12.2)

12.2

1		2		3		4	
5		6		7		8	
9		10		11		12	
13		14		15		16	

- 1.
2. () ?
3. ,
- 4.

13

13.1 *

(13.1) 3 (

13.1

1		2		3		4	
5		6		7		8	

9		10		11		12	
13		14		15		16	

13.2

(13.2)

13.2

1		2	
3		4	
5		6	
7		8	
9		10	
11		12	

13		14		15	
16		17		18	

15.2

(15.2)

, 10 - 15

15.2

1		2	
3		4	
5		6	
7		8	
9		10	
11		12	

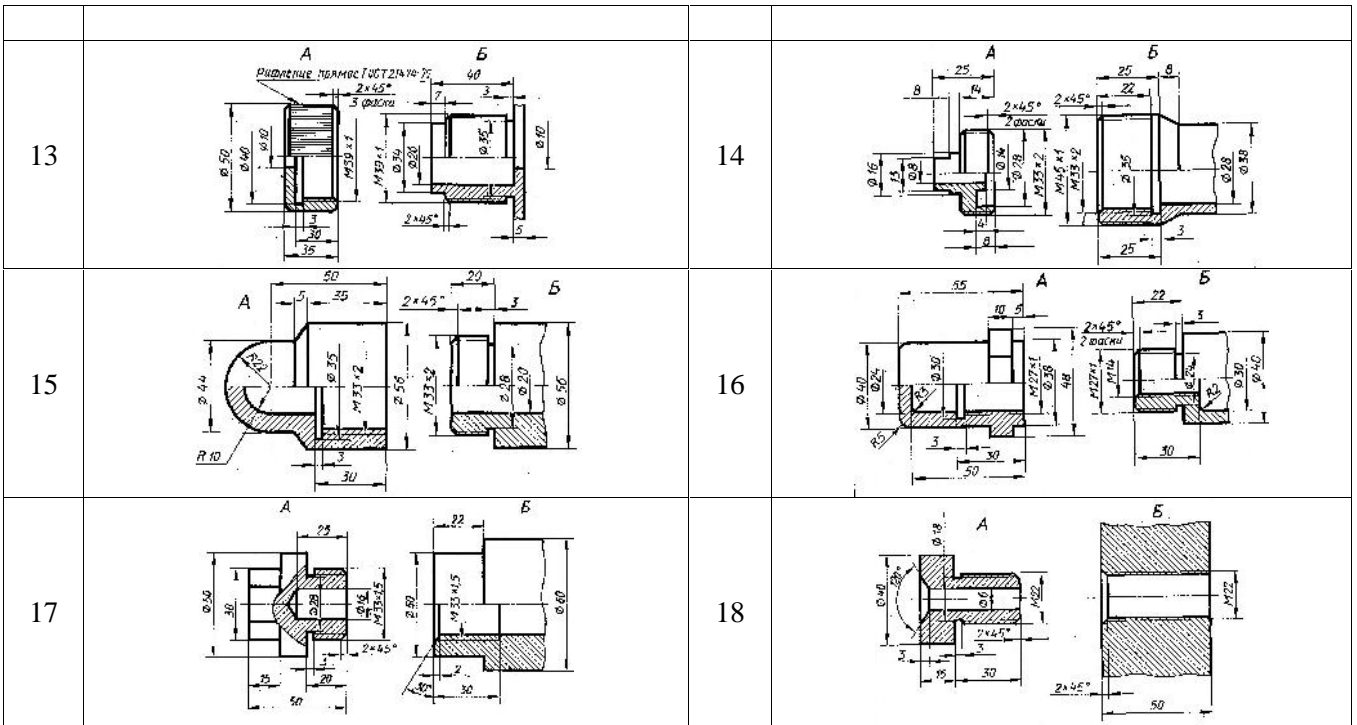

- 1.
- 2.
- 3.
- 4.

16

16.1

4

№ п/п	Обозначение	Изменения	Кол.	Примечание
1	6.6.8	70	63	10 22
210				
2	7.10	22 10 10	185	
110				
210				

16.2

4

№ п/п	Обозначение	Изменения	Кол.	Примечание
1	6.6.8	70	62	19 22
210				
2	7.10	22 10 10	110	
210				

- 1.
- 2.
- 3.

« ? » ?

17

17.1

1. () ?
2. ?
3. .

1	:	1 2 3 4, 5, 6, ...
2	,	X, Y, Z ...
3	,	0
4		, , 1, 2, 3
5		h, f, p, n, m, ...
6		AB, CD, ...
7		Γ , , ...
8	,	2, 2, ... 1, 1, ... 3, 3, ... 4, 5, 4, 5 ...
9	:	$h_2, f_2, p_2, n_2, \dots$ $h_1, f_1, p_1, n_1, \dots$ $h_3, f_3, p_3, n_3, \dots$ $h_4, f_4, p_4, n_4, \dots$
10	:	$2\ 2, \ 2D_2, \dots$ $1\ 1, \ 1D_1, \dots$ $3\ 3, \ 3D_3, \dots$ $4\ 4, \ 5D_5, \dots$
11	:	$\Gamma_2, \ 2, \dots$ $\Gamma_1, \ 1, \dots$ $\Gamma_3, \ 3, \dots$ $\Gamma_4, \ 5, \dots$
12	,	$\Gamma, \ , \dots$
13		\perp
14		//
15	()	
16		\cap
17		=
18		\angle
19		\perp
20		\in
21		\rightarrow
22		\neq

6.

1. / . . . , — ISBN 978-5-8114-7019-8. — : // : — URL: <https://e.lanbook.com/book/153958> (: 19.04.2023). — : . <https://reader.lanbook.com/book/153958>
2. / . . . — 2- . . . — ISBN 978-5-507-46137-0. — : // : — URL: <https://e.lanbook.com/book/298523> (: 19.04.2023). — : . <https://reader.lanbook.com/book/298523>

_____ " " " " [] / . . . ; . . . , 2019. - 41 . - 86/20. - 27.08 . . . : . http://lib.belgau.edu.ru/cgi-bin/irbis64r_plus/cgiirbis_64_ft.exe?S21COLORTERMS=0&LNG=&Z21ID=GUEST&I21DBN=BOOKS_FULLTEXT&P21DBN=BOOKS&S21STN=1&S21REF=10&S21FMT=briefHTML_ft&S21CNR=5&C21COM=S&S21ALL=%3C.%3EI=%D0%9611%2F%D0%91%2048%2D406134440%3C.%3E&US21ALL=1

1. , . . . : / . . . , . . . ; . . . , 2022. — 276 . — ISBN 978-5-507-44203-4. — : // : — URL: <https://e.lanbook.com/book/217451> (: 19.04.2023). — : . <https://reader.lanbook.com/book/217451>
2. / . . . , — ISBN 978-5-8114-7019-8. — : // : — URL: <https://e.lanbook.com/book/153958> (: 19.04.2023). — : . <https://reader.lanbook.com/book/153958>